



MODEL 9200D

LOW FREQUENCY PORTABLE SHAKER TABLE

- Verify Alert and Alarm Settings
- Simulate Vibration at Actual Running Speeds
- Rugged, Lightweight, and Battery-Powered Design
- On-Site ISO 5041 HVM Calibrations
- Confirm Entire Measurement Channel
- Proximity Probe Adaptor Kit

TYPICAL APPLICATIONS

- Hydro and Nuclear Power
- Human Vibration Measurement
- Seismic, Building Vibration
- Moving Coil Vibration Sensors
- Condition Monitoring System, Process Control, DCS and SCADA
- Portable Vibration Meters and Analyzers

CONFIRM VIBRATION ALARMS

The 9200D Low Frequency Portable Shaker Table is the world's first and only ISO 17025 accredited, NIST-traceable portable shaker table designed for verifying critical vibration instrumentation used to protect slow speed rotating equipment. Until now, technicians were required to remove moving coil velocity sensors, low frequency accelerometers, and proximity probes during an outage and send these instruments to a separate lab for calibration. Battery-powered, rugged and portable, the Model 9200D brings low frequency calibration to the plant floor, allowing users to verify all aspects of their measurement chain and confirm correct operation of critical alarm thresholds.

An internal high-resolution quartz reference accelerometer provides unparalleled accuracy while the rugged carbon fiber composite armature supports heavy payloads. A durable Pelican® Storm Case and long battery life make it ideal for use on the plant floor. Closed-loop control shortens calibration time. The 9200D can be scaled in displacement, velocity or acceleration (metric or English units) with 0.7 Hz to 2 kHz frequency range (42 to 120 000 CPM).

SPECIFICATIONS		
Performance		
Frequency Range (operating, 100-gram payload)	0.7 Hz to 2 kHz	42 to 120k CPM
Max Acceleration (100 Hz, no payload)	2 g pk	19.6 m/s ² pk
Max Velocity (10 Hz, no payload)	12 in/s pk	305 mm/s pk
Max Displacement (1 Hz, no payload)	200 mils pk-pk	5 mm pk-pk
Maximum Payload ^[1]	800 grams	
Accuracy of Readout		
Acceleration and Velocity (2 Hz to 2 kHz) ^{[2] [5]}	±3 %	
Acceleration and Velocity (0.7 Hz to 2 kHz) ^{[2] [5]}	±10 %	
Displacement (3 Hz to 15 Hz) ^[3]	±3 %	
Displacement (1 Hz to 150 Hz) ^[3]	±10 %	
Displacement (0.7 Hz to 150 Hz) ^[3]	±2 dB	
Amplitude Linearity (100-gram payload, 100 Hz)	< 1 % up to 2 g pk	
Waveform Distortion (1 Hz to 5 Hz)	Typically < 15 %	
Waveform Distortion (>5 Hz to 20 Hz)	Typically < 10 %	
Waveform Distortion (>20 Hz to 2 kHz)	Typically < 7 %	
Units of Readout		
Acceleration (peak and RMS)	g	m/s ²
Velocity (peak and RMS)	in/s	mm/s
Displacement (peak to peak)	mils	µm
Frequency	Hz	CPM
Physical		
External Source In (max)	1 V AC RMS	
Monitor Reference Out	100 mV/g buffered internal reference output	
Internal Battery (sealed solid gel lead acid)	12 VDC, 4 amp hours	
AC Power (for recharging battery)	110–240 VDC, 50–60 Hz	
Input Power Rating from charger	18 VDC, 1 A	
Operating Battery Life ^[4]		
100 gram payload (100 Hz 1 g pk)	14 hours	
100 gram payload (1 Hz 0.02 g pk)	7 hours	
Operating Temperature	32 °F–122 °F	0 °C–50 °C
Dimensions (H x W x D)	8.5 x 12 x 10 in	22 x 30.5 x 28 cm
Weight	18 lb	8.2 kg
Sensor Mounting Platform Thread Size	¼-28	

Optional Accessories ^[5]	
9100-MNTKIT	Mounting accessory kit to adapt to ¼-28 threaded mounting platforms. Includes studs/inserts (¼-28, 10-32, 6-32 and 5-40) and bases (for adhesive, magnetic and custom thread patterns).
9105C	Transfer standard reference accelerometer and ICP [®] sensor signal conditioner, for calibration and system verification of the 9200 Series Calibrators.
9100-MPPA01	Proximity probe adaptor kit, supports probes with common case threads ranging from M6 to ¾ in. Includes Mitutoyo micrometer (metric) and 9100-PPA02 nickel-plated 4140 steel target.
9100-PPA01	Proximity probe adaptor kit, supports probes with common case threads ranging from M6 to ¾ in. Includes Mitutoyo micrometer and 9100-PPA02 nickel-plated 4140 steel target.
9100-PPA02	Target for 9100-PPA01 or 9100-MPPA01 proximity probe adaptor kit, nickel plated 4140 steel.
9100-PS01	18 V, 1 A power supply/charger for 9200 Series Calibrator, universal 100-240 VAC, 50/60 Hz.
9100-BAT01	Replacement battery for 9200 Series Calibrators.
Accessory Pouch	
Power Supply and Plug Adaptors, ¼-28 to ¼-28 Adaptor, 10-32 to ¼-28 Adaptor and Mounting Pad. Ships with ship-ping lock (remove before use).	

- [1] Operating range reduced at higher payloads. Reference manual for full details.
 [2] Measured with 66-gram quartz reference accelerometer.
 [3] Measured with laser displacement interferometer.
 [4] As shipped from factory in new condition.
 [5] Depending upon payload at higher frequencies, transverse motion may cause localized increased measurement uncertainty.

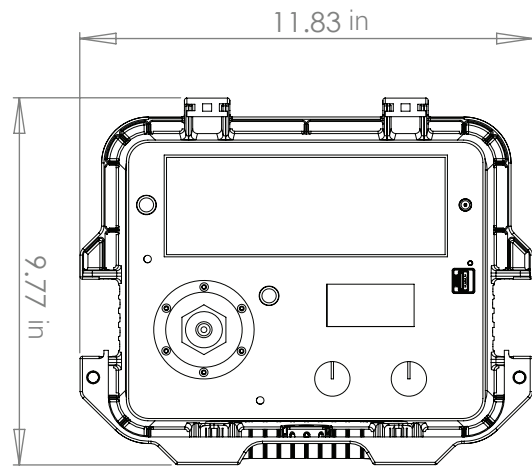

Model 9200
 Technical Drawing