



## MODEL 9917C

# MICROPHONE COMPARISON CALIBRATOR

- Validate microphones over a broad frequency range in the field or in the lab
- Simple, fast broadband acoustic calibration
- Reduces damage risk by leaving grid cap on
- Adheres to international standards
- Compatible with both condenser and array microphones

## TYPICAL APPLICATIONS

- Noise source identification
- Automotive NVH
- Flight test acoustics
- Vibro-acoustic testing
- Consumer and white goods product development
- Accredited metrology labs

## SIMPLIFIED MICROPHONE CALIBRATION

Model 9917C is a Microphone Comparison Calibrator that may be used for both precision condenser microphones and electret array microphones according to IEC 61094-5. To do so, the 9917C has 2 microphone ports—one each for a reference microphone and a test microphone (also known as Microphone Under Test). Adaptors are included for ¼” condenser microphones. These ports and adaptors are also designed for ‘array’ microphones. Rather than directly exposing the microphone diaphragm to the environment, as required by electrostatic actuator techniques, the 9917C operates with the grid cap remaining on the microphone. This reduces the risk of damage to the microphone diaphragm, and enables calibration of microphones with permanent grid caps.

These microphones experience the same acoustic input created by the internal actuator of the 9917C. The internal actuator creates an acoustic output proportional to a voltage input. This voltage input is provided by the user to the BNC jack on the 9917C. By using the known sensitivity of the reference microphone, and comparing the voltage output of both microphones, the sensitivity of the test microphone may be calculated.

Coupled with The Modal Shop’s 9000A SmartSine™ Calibration Driver, shown in the above right picture, microphones can be quickly and easily validated in the field or calibrated in the lab.

## SPECIFICATIONS

### Performance

Frequency Range	20 Hz to 10 kHz <sup>[1]</sup>
Microphone Pressure Calibration Accuracy <sup>[2]</sup>	±0.5 dB
Source Signal for 1 Pa Output (250 Hz)	2.6 mV
Source Signal for 1 Pa Output (1 kHz)	3.2 mV
Source Signal for 1 Pa Output (10 kHz)	500 mV
Distortion (%THD, 250 Hz, 94 dB SPL)	≤ 1%

### Physical

Maximum Input Voltage	2 V pk
Temperature Range (Operating)	40 °F to 122 °F (4.4 °C to 50 °C)
Temperature Range (Storage)	-40 °F to +176 °F (-40 °C to +80 °C)
Housing Material	Aluminum
Size (Length x Width x Height) <sup>[3]</sup>	4.7 x 1.6 x 1.6 inches (119 x 41 x 41 mm)
Source Input	BNC jack

[1] ≥ 94 dB SPL (re. 20e-6 Pa)

[2] This is the maximum expected difference of sound pressure between the two microphone diaphragms.

[3] Excluding BNC jack

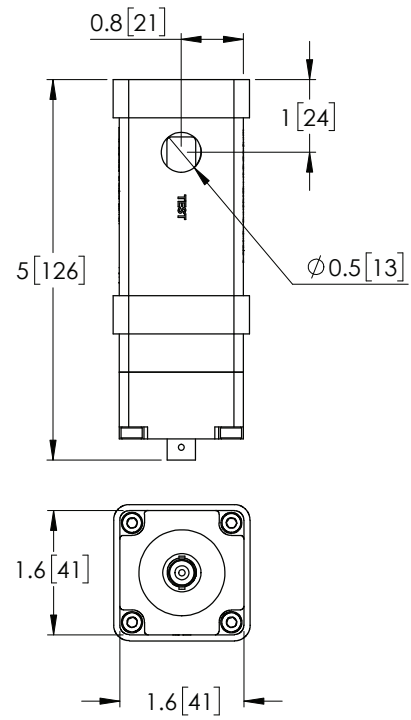

### Model 9917C

Technical Drawing

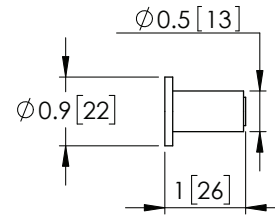

### Model PD-4348-01

¼" Microphone Adaptor  
Technical Drawing  
(Qty 2 Included)

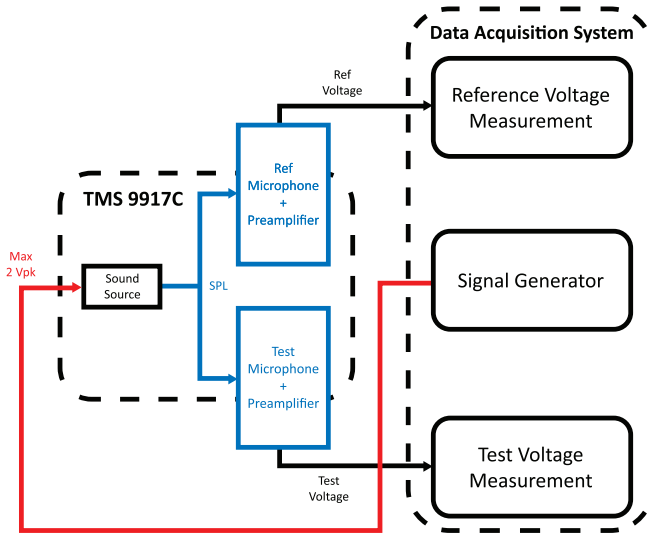

Block Diagram