

MODEL K2075E-HT/K2110E-HT

HORIZONTAL TABLE SHAKER KITS

- Available in 40 lbf (178 N), 75 lbf (334 N), and 110 lbf (489 N) configurations
- Test geophones and other vibration measurement monitoring devices
- Flexible design allows shaker to be detached from the table to be used in a traditional vertical vibration testing set-up or to take advantage of the through-hole armature for modal testing
- 6 in x 7.5 in (15 cm x 19 cm) table supports payloads up to 40 lb (18 kg)

SUPPORT LARGER LOADS

The Horizontal Table and Vibration Shaker combinations Model K2075E-HT and K2110E-HT expand the dynamic testing capabilities of The Modal Shop's 2075E and 2110E shakers, respectively. Horizontal Table Kits are specially designed to support loads not suitable for direct shaker attachment: test objects may be either larger or heavier than what can be directly mounted to a particular shaker or test specifications may require test objects to be oriented in a specific direction relative to gravity. In any of these situations, the Horizontal Table offers an easy-to-use, versatile solution.

The Horizontal Table has a 6 in x 7.5 in (15 cm x 19 cm) platform and can operate both horizontally and vertically. The table is carefully designed to remove any side loading from the shaker suspension and comes with pre-drilled inserts to facilitate easy test article attachment.

The Horizontal Table is available in a kit with either the 2075E or 2110E Shaker Systems. The K2075E-HT (75 lbf/334 N) and the K2110E-HT (110 lbf/489 N) kits include their respective shaker, horizontal flexure table, shaker mounting base for vertical and horizontal operation, power amplifier, and cooling package. The shaker can also be disconnected from the table, rotated to the vertical position and used in a traditional vibration testing set-up. A general purpose 10-32 mounting accelerometer can be added to the end of the table for feedback loop vibration control.

SPECIFICATIONS

Performance	K2075E-HT	K2110E-HT
Shaker	2075E	2110E
Amplifier	2050E09	2050E09-FS
Cooling Package	2000X04	2000X04
Force Rating, Sine (pk)	75 lbf (334 N)	110 lbf (489 N)
Force Rating, Random (RMS)	28 lbf (120 N)	45 lbf (200 N)
Max. Bare Table Acceleration, Sine (pk)	20 g	29 g
Bare Table Resonance Frequency	3000 Hz	
Maximum Useable Frequency	4500 Hz	
Maximum Displacement	1 in pk-pk	
Maximum Table Mounting CG Moment	50 in lbf (5.6 N m)	
Maximum Table Payload Capacity	40 lb (18 kg) ^[1]	
Physical		
Flexure Table Mass	2.8 lb (1.27 kg)	
Shaker Armature Mass	1.0 lb (0.45 kg)	
Total Moving Mass	3.8 lb (1.75 kg)	
Table Mounting Surface (length x width)	6 in x 7.5 in (15 cm x 19 cm)	
Overall Dimensions	18.4 in x 9.1 in x 7.5 in (47 cm x 23 cm x 19 cm)	
Table Mounting Hole Thread Options	10-32 ^[2]	
Table Mounting Hole Pattern (inserts)	1 in (25.4 mm) square grid	
Total Weight	70 lb (32 kg)	100 lb (45 kg)
Supplied Accessories		
Shaker cable to amplifier, rubber isolation mounts, handles, screws and tools		
Optional Accessories		
2000X01	Head Expander, M2000X01 Head Expander (M5)	
J352C33	Ground Isolated Accelerometer (100 mV/g)	
2000X03	Shaker Accessory Kit	

[1] Standard table configuration

[2] 10-32 standard, M5 option available

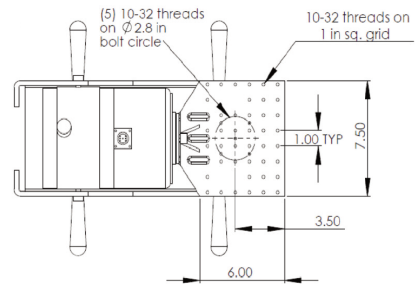

Top View

Dimensions in inches

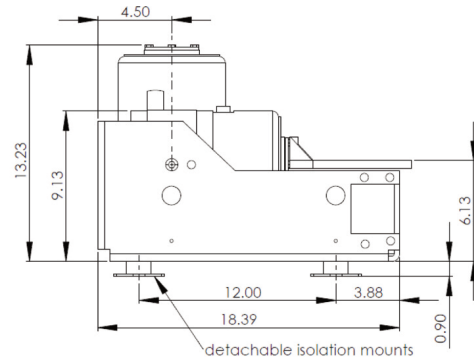

Side View

Dimensions in inches

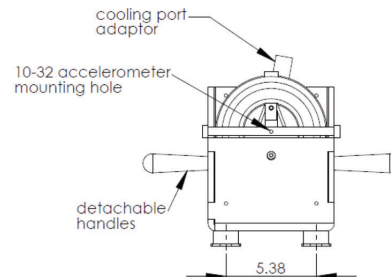

Front View

Dimensions in inches