



MODEL K9901C

HIGH FREQUENCY SHOCK TUBE

- Measures resonant frequency of pressure sensors
- Estimates high frequency response of pressure sensors
- Enables high frequency sensitivity calculation

TYPICAL APPLICATIONS

- Explosive ordnance disposal suit research
- Body armor research
- Research & development

LAB ACCURACY TO THE FIELD

The Model K9901C Shock Tube performs dynamic characterizations on a wide range of pressure sensors. The Model K9901C produces a shock wave by the sudden burst of a replaceable diaphragm. By measuring the timing of the shock wave, as well as measuring the ambient temperature, pressure, and relative humidity, engineers can calculate the sensitivity of a test sensor mounted in the end of the shock tube. The frequency response and resonant frequency of the test sensor may also be estimated as a result of this shock wave. In addition to the shock tube hardware, K9901C includes a pre-installed data acquisition system and software.

This high speed data acquisition software:

- Records, saves, and recalls pressure and weather data
- Maintains a database of equipment used for each test
- Controls data acquisition hardware parameters

APPROXIMATE SHOCK PRESSURES AS A FUNCTION OF DIAPHRAGM

Required Driver Pressure (psi [kPa])	Incident Shock Pressure (psi [kPa])	Reflected Overpressure (psi [kPa])	Diaphragm Material	Diaphragm Material Thickness (in [mm])	Driver Gas
1400 [9700]	180 [1200]	1050 [7200]	Aluminum	0.064 [1.6]	Helium
880 [6100]	144 [1000]	790 [5400]	Aluminum	0.04 [1]	Helium
760 [5200]	130 [900]	690 [4800]	Aluminum	0.032 [0.8]	Helium
423 [2900]	90 [600]	435 [3000]	Aluminum	0.02 [0.5]	Helium
760 [5200]	58 [400]	245 [1700]	Aluminum	0.032 [0.8]	Nitrogen
225 [1600]	32 [200]	110 [800]	Mylar ^[1]	0.01 [0.3]	Nitrogen
7 [50]	3 [20]	6.6 [50]	Mylar ^[1]	0.001 [0.03]	Air

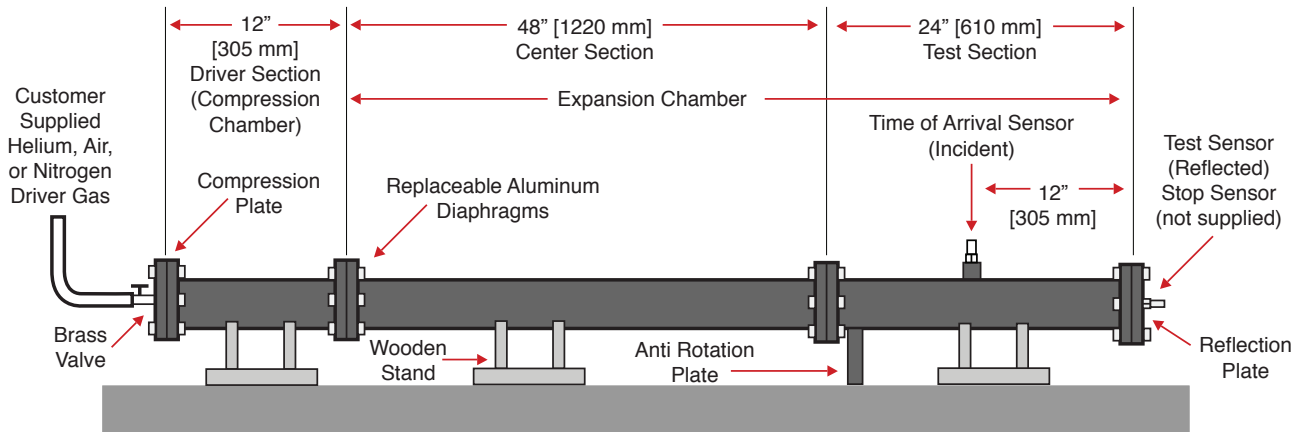

Shock Tube Diagram

SPECIFICATIONS

Physical

Driver Section Dimensions (Inner Diameter x Length)	2 in x 12 in	50 mm x 305 mm
Driven Section Dimensions (Inner Diameter x Length)	2 in x 72 in	50 mm x 1 829 mm
Driven Gas	Dry air	
Driver Gas	Dry air, helium, other inert gas	
Mounting Stand Footprint (Length x Width)	96 in x 11 in	2 438 mm x 280 mm
Incident Position Pressure Ports	QTY. 2	
Reflected Position Pressure Ports	QTY. 1–2 ^[2]	

[1] Mylar diaphragms may be stacked for higher pressure levels.

[2] Two separate end plates are included. One with a single port, and another with dual ports for side-by-side comparison testing.

SUPPLIED ACCESSORIES

Data Acquisition System and Pre-installed Software
ICP® Pressure Sensors, Signal Conditioning, and Cabling
Mounting Adaptors for Sensors with PCB 112 Series and 109 Series Form Factor
Consumable Diaphragms