

## MODEL RAM - DROP

# NDT-RAM DROP TEST SYSTEM

- Maximum throughput up to one part/s
- Tests many different part numbers on a single system
- No part preparation or elaborate fixturing required
- Easy-to-learn application software
- Automatic sorting of Pass and Fail parts
- Generates production reports for statistical analysis
- Easy integration with up/down stream automation components

## TYPICAL APPLICATIONS

- 100% Inspection
- Production - End-of-Line Inspection + Process Monitoring
- Quarantines - Troubleshooting
- Quality Control - Spot Checking
- Engineering - New Product Development

## 100% QUALITY INSPECTION FOR SMALL PARTS

The Drop Test System, Model RAM-DROP Resonant Inspection System, is an ideal choice for testing small powdered metal (PM), additively manufactured (AM) or other metal parts. The innovative Drop Test Fixture makes automation for 100% quality testing easy and efficient. With cycle times approximately 3 seconds per part, typical\*, the RAM-DROP provides a means for objective sorting, requiring no human interpretation. A simple pass/fail result is returned by the NDT-RAM system and parts are automatically sorted via a servo-controlled motor.

### Successful Applications:

- Powdered Metal
- Additive Manufacturing
- Metal Injection Molding
- Composites/Ceramics
- Small Metal Components
- And more

### Typical Defects Detected:

- Cracks
- Braze Quality
- Missing Features
- Missed Processes
- Mixed Material
- Heat Treat

The RAM-DROP automates easily with small part automation components like bowl feeders or vibratory tables and is instrumented with a laboratory grade force sensor, microphone and digital signal analyzer all designed to withstand a tough manufacturing environment. An industrial PC, mounted on a convenient swivel arm, provides software interface control.

This easy-to-use Non-destructive-testing system quickly becomes a critical quality assurance tool in your inspection process. The RAM-DROP can detect imperfections or flaws such as variations in overall geometry, cracks, and missing features. It can also detect if processes have been missed, such as machining or heat treating operations.

# NDT-RAM SOFTWARE

NDT-RAM application software compares each part's resonant signature against reference criteria limits and accepts or rejects the part accordingly. The system report generation feature allows for full part signature archival and statistical analysis of your parts and manufacturing processes. The software offers:

- Graphical features provide visual data evaluation
- Color coded spectra to show good and bad parts against preset acceptable criteria ranges
- An Investigate Mode supports up to 1500 part spectra, labeled good, bad or unknown
- Clear indication of pass/fail as each part is tested

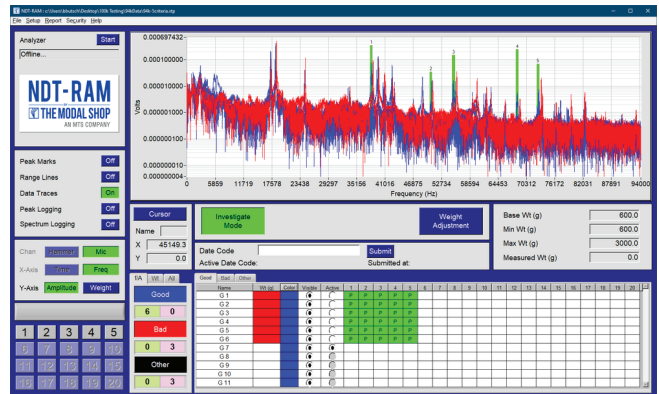

NDT-RAM Software Interface

SPECIFICATIONS	
<b>Performance</b>	
Part Throughput	
Cycle Time (Typical)	Approximately 3 seconds per part, typical* (Max Throughput 1 part/s)
Maximum Part Size	5 inches (10.16 cm), < 200 g
Pass/Fail Mechanism	
User Defined Criteria Ranges	Up to 20 frequency bands
Rejection/Approval Mechanics	Servo-Controlled motor
Acoustic Measurement	
Response Sensing	Prepolarized microphone - PCB 130 series
Frequency Range	Up to 50 kHz
System Control	
PLC Servo Controller	16 inputs/16 outputs modular expandable
Computer	Siemens Industrial PC

\*Part throughput rate dependent upon part size, data acquisition set-up parameters, and other part handling considerations.

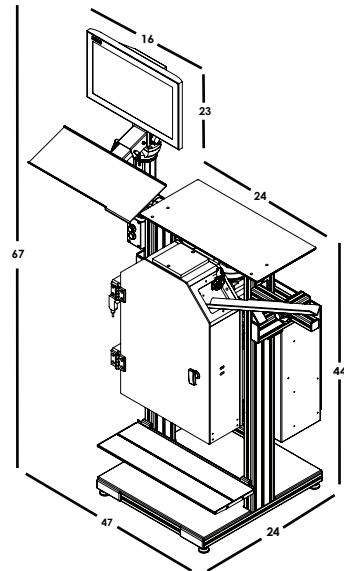

NDT-RAM Drop Test System  
Dimensions in inches



10310 Aerohub Boulevard, Cincinnati, OH 45215 USA

modalshop.com | info@modalshop.com | 800 860 4867 | +1 513 351 9919

© 2021 PCB Piezotronics - all rights reserved. PCB Piezotronics is a wholly-owned subsidiary of Amphenol Corporation. Endevo is an assumed name of PCB Piezotronics of North Carolina, Inc., which is a wholly-owned subsidiary of PCB Piezotronics, Inc. Accumetrics, Inc. and The Modal Shop, Inc. are wholly-owned subsidiaries of PCB Piezotronics, Inc. IMI Sensors and Larson Davis are Divisions of PCB Piezotronics, Inc. Except for any third party marks for which attribution is provided herein, the company names and product names used in this document may be the registered trademarks or unregistered trademarks of PCB Piezotronics, Inc., PCB Piezotronics of North Carolina, Inc. (d/b/a Endevo), The Modal Shop, Inc. or Accumetrics, Inc. Detailed trademark ownership information is available at [www.pcb.com/trademarkownership](http://www.pcb.com/trademarkownership).